

2562118D REV. D 911

Safety Message to Installers and Service Personnel of Warning Light Equipment

▲ WARNING

People's lives depend on your proper installation and servicing of Federal Signal products. It is important to read and follow all instructions shipped with this product and the original product. In addition, listed below are some other important safety instructions and precautions you should follow:

- To properly install this device, you must have a good understanding of automotive electrical procedures and systems, along with proficiency in the installation and use of safety warning equipment.
- DO NOT install equipment or route wiring in the deployment path of an airbag.
- If a vehicle seat is temporarily removed, verify with the vehicle manufacturer if the seat needs to be recalibrated for proper airbag deployment.
- When drilling into a vehicle structure, be sure that both sides of the surface are clear of anything that could be damaged.
- In order for the device to function properly, a good ground connection must be made. At a minimum, it must be attached to a solid metal body or chassis part that will provide an effective ground path as long as the light system is to be used.
- Locate light control so the VEHICLE and CONTROL can be operated safely under all driving conditions.
- Do not attempt to activate or deactivate light control while driving in a hazardous situation.
- This product controls high intensity lighting devices. To prevent eye damage, DO NOT stare into the light beam at close range.
- You should frequently inspect the light to ensure that it is operating properly and that it is securely attached to the vehicle.
- File these instructions in a safe place and refer to them when maintaining and/or reinstalling the product.

Failure to follow all safety precautions and instructions may result in property damage, serious injury, or death.

Overview

The Model 330104 SMC1 is a directional light controller. It is designed to operate the full selection of Federal Signal SignalMaster® directional lightbars from four to eight light heads, either continuous or split, at 12 V or 24 V. The control circuitry is protected against reverse polarity by a 2 A fuse and a diode. The lightbar requires its own appropriately-sized fuse.

This model provides six distinctive directional signals. There are standard left-arrow, center-out, and right-arrow patterns as well as special left-arrow, center-out, and right-arrow patterns that comply with CAC Title 13, Article 22 if used with the appropriate SignalMaster directional lightbar in Tables 1 and 2 on page 2.

Table 1 Halogen SignalMaster directional warning lights
(for CAC Title 13, Article 22 compliance)

Model	Length	Lamps	Cable	Lenses
320142	20 in	4	30 ft	Amber
320162	31 in	6	15 ft	Amber
320612	31 in	6	30 ft	Amber
320172	42 in	8	15 ft	Amber
320182	42 in	8	30 ft	Amber
320192	42 in	8	50 ft	Amber
320602	84 in	8+ DOT Strip	35 ft	Amber

Table 2 VPX SignalMaster directional warning lights
(for CAC Title 13, Article 22 compliance)

Model	Length	Lamps	Cable	LEDs	Lenses
320900	20 in	4	30 ft	Amber	Amber
320905	31 in	6	15 ft	Amber	Amber
320910	31 in	6	30 ft	Amber	Amber
320915	31 in	6	60 ft	Amber	Amber
320920	42 in	8	15 ft	Amber	Amber
320925	42 in	8	30 ft	Amber	Amber
320930	42 in	8	60 ft	Amber	Amber
320935	51 in	8	30 ft	Amber	Amber
320940	51 in	8	50 ft	Amber	Amber

The WARN function provides a non-directional flash pattern for use when a directional signal may not be appropriate. One pattern can be selected from the ten patterns available, which include seven standard patterns and three patterns compliant with CAC Title 13, Article 22. Some patterns are optimized for LED products and flash too fast for a halogen lightbar. The default pattern is the classic SMC warn pattern with four center lighthoods alternating with the two lighthoods on each end.

When standard directional signal operation is selected, the lamps illuminate sequentially in a sweeping motion until all are illuminated and then repeat. When Title 13 Mode is selected, the lamps are extinguished more quickly than in standard mode. Title 13 Mode provides patterns that comply with the 40 percent to 60 percent on-time and flash rate of 60 FPM to 120 FPM, which are requirements of CAC Title 13, Article 22.

Although the controller operates at 12 Vdc to 24 Vdc, ensure that the SignalMaster lightbar is of the proper voltage for the electrical system of the vehicle. Do not operate a 12 V SignalMaster at 24 V or a 24 V SignalMaster at 12 V, or shortened lamp life will result.

Model 330104 Controller Specifications

Electrical

Input Voltage:	11 Vdc to 28 Vdc
Polarity:	Negative ground only
Operating Temperature Range:	-30 °C to +65 °C
Standby Current:	7 mA (0.007 A)
Lightbar Fuse:	20 A, installer-provided
+IGNITION Fuse:	2 A
Output Drive Capability (Total):	Eight 27 W lamps on 8 channels
Normal Directional Flash Rate:	Approximately 30 patterns per minute

Dimensions

Height:	1-1/2 in
Width:	6-1/8 in
Depth:	5 in
Shipping Weight:	2.5 lb

Table 3 Parts list

Qty.	Description	Part No.
1	Controller	330104
1	Terminal Spade, Blue, #10, 16–14 AWG	224298
1	Mounting Bracket	8573070
2	Lockwasher, Ext. Tooth, 1/4"	7075A007
2	Screw, Hex Head, 1/4"-20, Taptite	7011164-08

Installing the SignalMaster Lightbar

Install the light assembly as described in the instructions included with the SignalMaster. Route the cable to the planned location of the controller.

Installing the Mounting Bracket for the Controller

The supplied mounting bracket allows the controller to be mounted in a variety of positions. To install the mounting bracket:

NOTICE

CONTROLLER REQUIRES VENTILATION—*This controller needs to radiate heat. Do not install the unit in an area where it cannot dissipate heat into the air. Do not mount the unit near a heater duct.*

1. Select a mounting location for the controller that allows the vehicle and controls to be operated safely at all times.
2. Use the mounting bracket as a template and scribe two drill-position marks at the selected mounting location. See Figure 1 on page 4.

NOTICE

DRILLING PRECAUTIONS—When drilling holes, check the area into which you are drilling to be sure that you do not damage vehicle components. All drilled holes should be deburred and all sharp edges should be smoothed. All wire routing going through drilled holes should be protected by a grommet or convolute/split-loom weaving.

3. Drill a hole sized for the installer-provided hardware to be used in step 4 at each drill-position mark.
4. Secure the mounting bracket to the mounting surface with two installer-supplied, thread-forming, 1/4" screws or other hardware appropriate for the installation.
5. Before fastening the controller to the bracket, continue with the electrical connections as described in the next sections.

Figure 1 Bracket positions and hardware

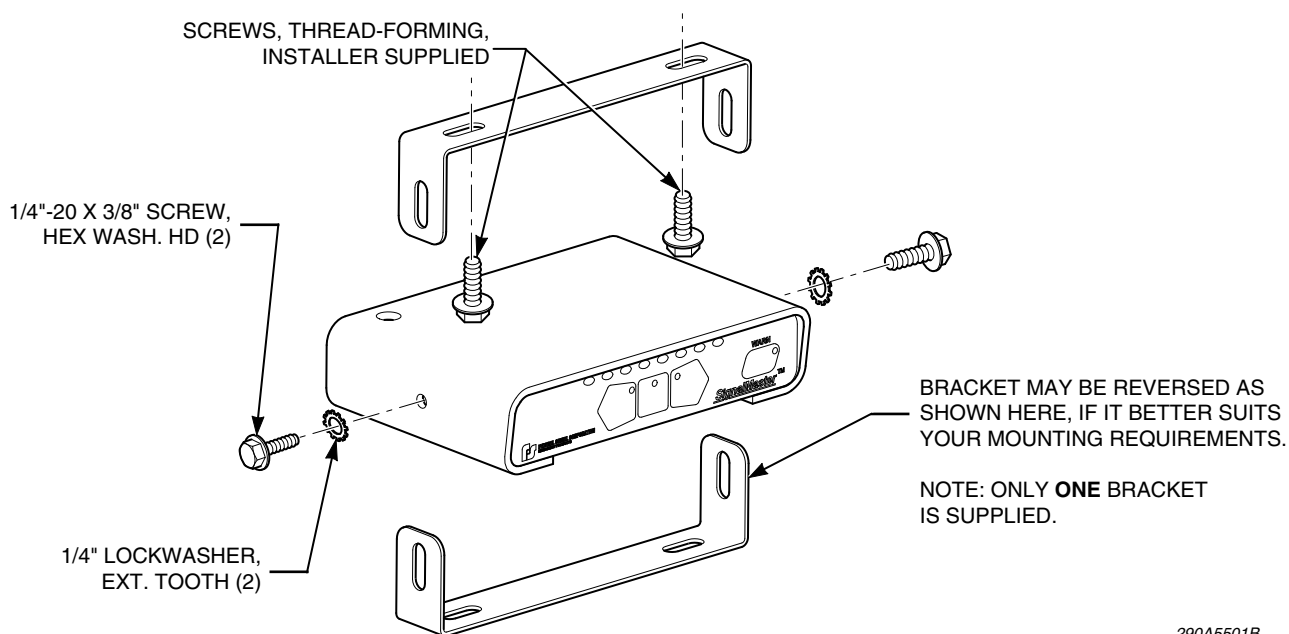

Connecting Power to the Controller

⚠ WARNING

HIGH-CURRENT ARCING—Do not connect this system to the vehicle battery until all other electrical connections are completed, and you have verified no shorts exist. High current shorts can cause hazardous sparks or burning wire resulting in an electrical fire.

The controller is equipped with a nine-position terminal block and an insulated spade connector. Also required are installer-supplied red and black wires of the proper gauge for the current and run length of the specific installation. For the recommended wire gauge, see Table 4 on page 5. The ground wire should be sized to handle the total current used by the lightbar and controller. Connect the lightbar using a red wire of the appropriate gauge to a fused positive power source. Installer-supplied 18 AWG (minimum) red wire is required for the connection of the controller to the positive power source.

To make the power connections to the controller:

1. Strip 1/4" of insulation from the main ground wire and crimp the proper spade connector onto it.

⚠ WARNING

BATTERY EXPLOSION—To avoid a battery explosion, always disconnect the negative battery cable first and reconnect it last. Avoid causing a spark when connecting near or to the battery. The gases produced by a battery can cause a battery explosion that could result in vehicle damage and serious injury.

NOTICE

CONNECTING THE RED AND BLACK WIRES—To avoid damage and ensure proper operation, the red and black wires **MUST** be installed as shown in Figure 2 on page 6.

2. Connect the black ground wire to the lug as shown in Figure 2 on page 6. Securely tighten the binding screw using a 1/4" flat-tip screwdriver passing through the opening in the cover.
3. Route the ground wire through the firewall and toward the battery. Connect it to a good frame ground near the battery. For gauge recommendations, see Table 4. In most vehicles a wire from the negative terminal of the battery is routed and attached to the screw at the body/frame at the fender.

Table 4 Minimum wire gauge

Distance to Battery	20 A Peak
5 ft	18 AWG
10 ft	16 AWG
20 ft	12 AWG
30 ft	12 AWG
40 ft	10 AWG

4. Connect the red wire from the nine-conductor cable of the SignalMaster to the vehicle battery through a 20 A fuse holder that is located as close to the battery as possible. **Do not install the fuse until all other electrical connections have been made.** To run between the fuse and the SignalMaster, use a properly-sized red wire. For wire gauge recommendations, see Table 4.
5. Select a termination point for the 18 AWG red power wire from the controller. As applicable, route the 18 AWG red wire toward the vehicle fuse block or through the firewall toward the battery. If the controller power is to be connected to the battery, install a installer-supplied, in-line fuse in the 18 AWG red wire as close to the battery as possible and terminate it as required. If the red wire is to be terminated to the fuse block, select an appropriate fused circuit.

IMPORTANT: The termination point of the 18 AWG red wire from the controller determines when the directional signal can be activated. When the wire is attached to a vehicle fuse that is powered when the ignition switch is in the run or start position, the ignition switch must be in the run position to operate the directional signal. When the wire is attached to the vehicle battery, the directional signal can be operated at any time. To avoid draining the battery, Federal Signal recommends that the power wire from the controller be terminated to a switched source. **NOTE:** The controller draws 7 mA (0.007 A) in the off position when connected directly to the vehicle battery.

- Strip 1/4" of insulation from all of the wires that will enter nine-position the terminal block. Make all of the required connections to the terminal block as described in the next section.
- Connect the 18 AWG red wire to the position labeled on the terminal block for +12-24 Vdc.

Wiring the Six- and Eight-Head SignalMaster

To wire the SignalMaster:

- Connect the colored wires from the nine-conductor cable to the locations specified in Figure 2 or on the label affixed to the controller housing.

NOTE: With the six-head SignalMaster lightbar, the white and blue wires are not needed and can be cut even with the cable sheath.

- For split SignalMasters where two-, three- or four-head assemblies make up a full eight- or six-head SignalMaster assembly, connect the wires to the terminal blocks in order from left to right. The output labeled BLUE on the controller is for the rightmost lamp, and the one labeled WHITE is for the leftmost lamp.
- When all electrical connections are completed, insert a 20 A fuse into the fuse holder in the SignalMaster red power wire.

Figure 2 Wiring from SignalMaster to controller

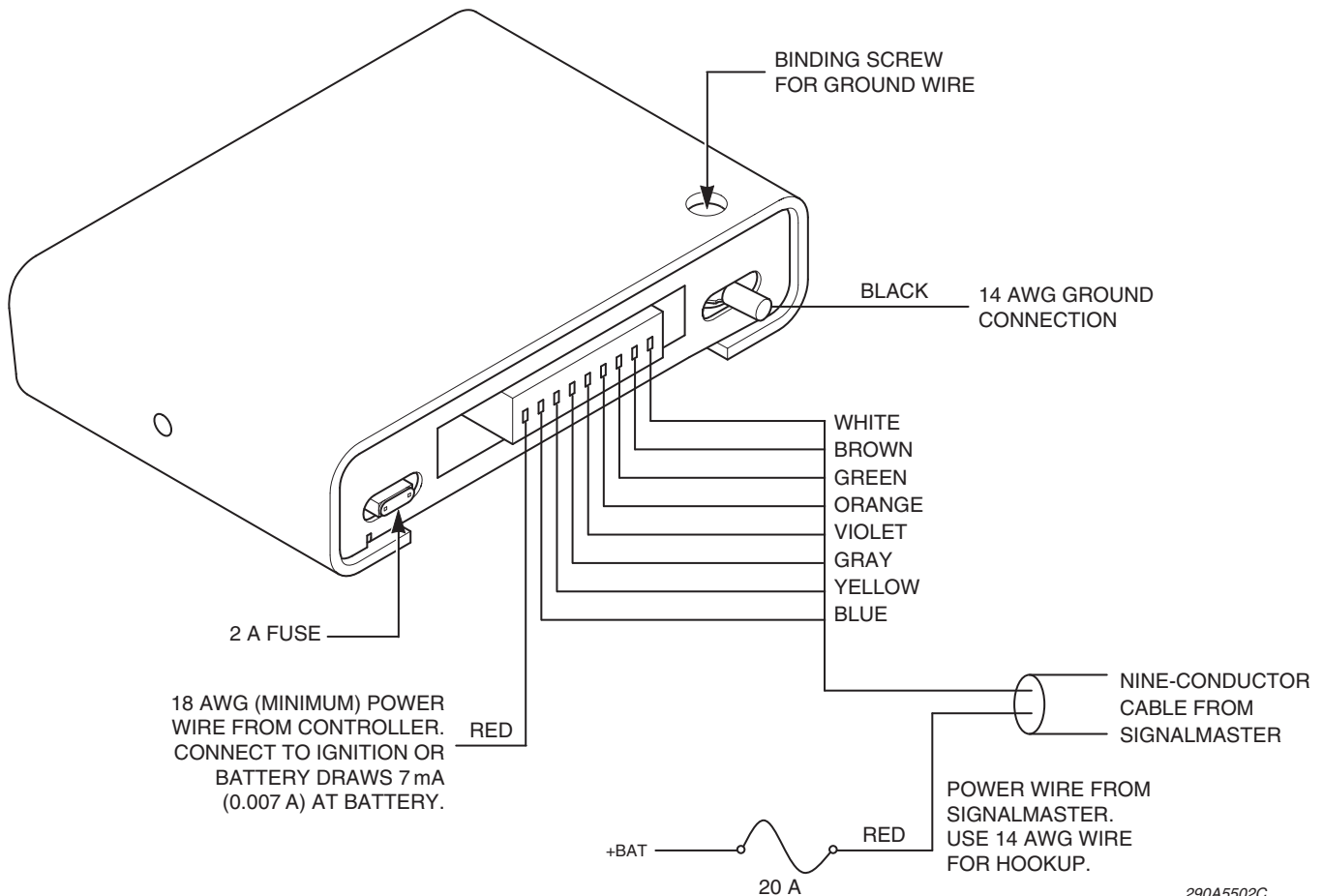

Mounting the Controller

To fasten the controller to the bracket:

1. Place the controller into the mounting bracket (Figure 1 on page 4).
2. Fasten the controller using the two self tapping screws provided.
3. Angle the controller for optimum visibility from the operators position before tightening the screws.
4. Dress the cables and wires, and secure them out of the way.

Configuring the Controller

The controller has several installer-selectable warning patterns that you can select after the installation and wiring of the SignalMaster system is complete. For the functions of the controller buttons, see Figure 3 and “Operating the SignalMaster Controller” on page 9.

Figure 3 Model 330104 SMC1 controller

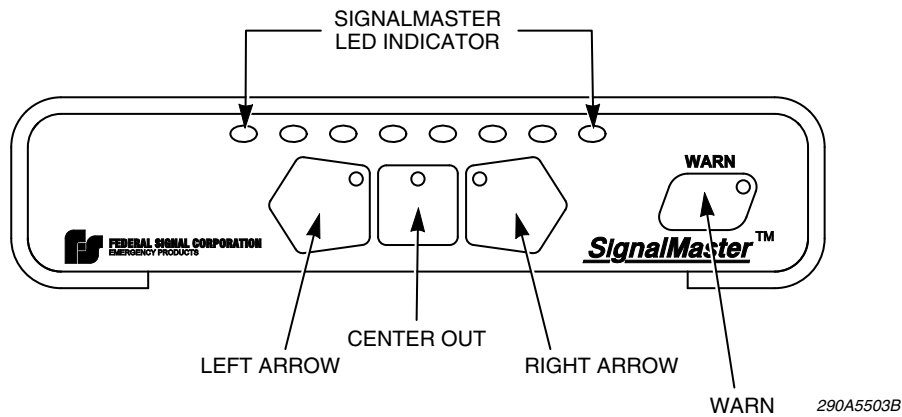

Table 5 Standard warn patterns

Pattern No.	Description
0	Null (no pattern)
1	Center lights alternate with lights at each end
2	The lights alternate on each half of the lightbar
3	Moving triple flash
4	Quad flash with full bar accent
5	Random 1, single heads
6	Fast ripple out
7	Random 2

Table 6 Warn patterns compliant with CAC Title 13, Article 22

Pattern No.	Description
0	Null (no pattern)
1	Alternating, two-head flash on each end
2	Alternating in/out
3	Alternating odds/evens

Entering Program Mode

With the vehicle ignition turned on and the directional light turned off, press the LEFT ARROW and CENTER OUT buttons simultaneously. Both buttons remain lit indicating that the controller is now in Programming Mode. Select one or more of the following options before exiting Program Mode. See “Exiting Program Mode” at the end of this section.

- **Selecting a Six- or Eight-Head Output**

To select a six- or eight-head output for six- or eight-head SignalMasters, press the LEFT ARROW button until the correct number of lighthoods flashes simultaneously. The indicator LEDs on the controller mimic the pattern of flashing heads on the SignalMaster.

- **Selecting a Standard Warn Pattern**

In the default Standard Mode, each time the WARN button is pressed, the active warn pattern changes to the next in the sequence. See Table 5 on page 7 for a description of the flash patterns.

- **Selecting a Split or Standard Lightbar**

To select a split SignalMaster (three- or four-head lightbars) or a standard SignalMaster, press the CENTER OUT button to toggle between split or standard mode.

- **Selecting Title 13 Mode**

To select Title 13 Mode, press the RIGHT ARROW button. The indicator LEDs and the SignalMaster lightbar display a more fluid pattern in which the lights extinguish sooner to comply with the light/dark timing requirements of Title 13. To select a different warn pattern, press the WARN button to display the next pattern in the sequence. For a description of the non-directional warn patterns, see Table 6 above.

To return to Standard Mode, press the RIGHT ARROW button.

Exiting Program Mode

To exit Programming Mode, temporarily interrupt the power to the controller by turning off the vehicle ignition or removing the power fuse, depending the termination point of the 18 AWG wire.

Safety Message to Operators of Warning Light Equipment

⚠ WARNING

Peoples' lives depend on your safe use of our products. Listed below are some important safety instructions and precautions you should follow:

- Do not attempt to activate or de-activate the light system control while driving in a hazardous situation.
- Although your warning system is operating properly, it may not be completely effective. People may not see or heed your warning signal. You must recognize this fact and continue driving cautiously.
- Also, situations may occur which obstruct your warning signal when natural or manmade objects are between your vehicle and others, such as: raising your hood or trunk lid. If these situations occur, be especially careful.
- This product controls high intensity LED devices. To prevent eye damage, DO NOT stare into the light beam at close range.
- At the start of your shift you should ensure that the light is securely attached and all lamps are operating properly. The LED display on the control only simulates the operation of the lamps.
- If a selected function does not perform properly or if any of the lamps remain illuminated when the control is off, disconnect the power connector from the controller and contact the nearest service center. Failure to follow these safety precautions may result in property damage, serious injury, or death.

Operating the SignalMaster Controller

See Figure 3 on page 7. All controls for the SignalMaster directional lights are located on the front panel of the controller. The LED display simulates the active light pattern.

Function Activation

The Model 330104 controller gives the function of the latest priority. If the RIGHT directional signal is active when the WARN button is depressed, the controller produces the warn pattern. It will then turn off the warn pattern if the WARN button is pressed a second time. If another button is pressed, then the function controlled by the newly pressed button becomes active. To turn off the function, the button must be pressed a second time.

LEFT ARROW Button

Displays a left-arrow flash pattern that instructs traffic to move left. The pattern is more fluid in Title 13 Mode.

CENTER OUT Button

Displays a center-out flash pattern that instructs traffic to move around either side of the vehicle.

RIGHT ARROW Button

Displays a right-arrow flash pattern that instructs traffic to move right. .

WARN Button

Displays a non-directional warning pattern. See Table 5 on page 7 and Table 6 on page 8 for available patterns.

Testing the Installation

⚠ WARNING

LIGHT HAZARD—*To be an effective warning device, an emergency warning system produces bright light that can be hazardous to your eyesight when viewed at a close range. Do not stare directly into the lights at a close range or permanent damage to your eyesight may occur.*

After testing the installation, test the emergency warning system to ensure that it is operating properly. Also test all vehicle functions, including horn operation, vehicle safety functions, and vehicle lighting systems to ensure proper operation. Ensure that the installation has not affected the vehicle operation or changed any vehicle safety functions or circuits.

Do not test the light system of the vehicle while driving. Operating the vehicle warning systems may pose a hazard to the operator and other drivers if the systems do not function as expected. Test the vehicle only in a controlled environment. After testing is complete, provide a copy of these instructions to the instructional staff and all operating personnel.

Getting Technical Support and Service

If the controller is not working properly, remove the fuses before disconnecting the wires from the unit to prevent shorts. Disconnect all electrical connections starting with the power leads. Remove the controller from the mounting bracket. See “Returning a Product to Federal Signal” for further instructions.

For technical support, contact:

Federal Signal Corporation
Service Department
Public Safety Systems
Phone: 1-800-433-9132
Fax: 1-800-343-9706
Email: empserviceinfo@fedsig.com

Ordering Replacement Parts

To order the replacement parts in Table 7, please contact your local dealer/distributor or:

Customer Support
Federal Signal Corporation
Phone: 1-800-264-3578

Table 7 Replacement parts

Qty.	Description	Part No.
1	Controller	330104
1	Terminal Spade. #10, 16–14 AWG	224298
1	Mounting Bracket	8573070
2	Lockwasher, Ext. Tooth, 1/4"	7075A007
2	Screw, Hex Head, 1/4"-20, Taptite	7011164-08

Returning a Product to Federal Signal

Before returning a product to Federal Signal, call 800-264-3578, 800-433-9132, or 800-824-0254 to obtain a Returned Merchandise Authorization number (RMA number). To expedite the process please be prepared with the following information:

- Your Federal Signal customer or account number.
- The purchase order number under which the items were purchased.
- The shipping method.
- The model or part number of the product being returned.
- The quantity of products being returned.
- Drop ship information as needed.
- Any estimate required.

When you receive your RMA Number:

- Write the RMA number on the outside of the box of returned items.
- Reference the RMA number on your paperwork inside of the box.
- Write the RMA number down, so that you can easily check on status of the returned equipment.

Send all material with the issued RMA Number to:

Federal Signal Corporation
Public Safety Systems
2645 Federal Signal Drive
University Park, IL 60484-3167
Attn: Service Department
RMA: # _____
800-433-9132
800-343-9706 (fax)
www.fedsig.com



2645 Federal Signal Drive, University Park, IL 60484-3167

Tel.: (800) 264-3578 • Fax: (800) 682-8022

www.fedsig.com

© 2011 Federal Signal Corporation
SignalMaster is a registered trademark of Federal Signal Corp.