

INSTALLATION AND MAINTENANCE INSTRUCTIONS
FOR
LAPD ARJENT™ SL LED/HALOGEN LIGHT ASSEMBLY

SAFETY MESSAGE TO INSTALLERS
OF
FEDERAL SIGNAL LIGHT SYSTEMS

 **WARNING**

People's lives depend on your safe installation of our products. It is important to read, understand and follow all instructions shipped with the products. In addition, listed below are some other important safety instructions and precautions you should follow:

- **To properly install a light assembly: you must have a good understanding of automotive electrical procedures and systems, along with proficiency in the installation and use of safety warning equipment.**
- **When drilling into a vehicle structure, be sure that both sides of the surface are clear of anything that could be damaged.**
- **A light system is a high current device. In order for it to function properly, a separate ground connection must be made. If practical, it should be connected to the negative battery terminal. At a minimum, it may be attached to a solid metal body or chassis part that will provide an effective ground path as long as the light system is to be used.**
- **Locate light system controls so the VEHICLE and CONTROLS can be operated safely under all driving conditions.**
- **This product contains high intensity LED devices. To prevent eye damage, DO NOT stare into the light beam at close range.**
- **You should frequently inspect the light system to ensure that it is operating properly and that it is securely attached to the vehicle.**
- **File these instructions in a safe place and refer to them when maintaining and/or reinstalling the product.**

Failure to follow all safety precautions and instructions may result in property damage, serious injury, or death to you or others.

I. **UNPACKING.**

After unpacking the Arjent lightbar, inspect it for damage that may have occurred in transit. If the unit has been damaged, file a claim immediately with the carrier, stating the extent of damage. Carefully check all envelopes, shipping labels and tags before removing or destroying them.

II. **INSTALLATION.**

NOTE

If the unit is supplied with the SignalMaster™ option, two cables exit the light bar. The larger cable is the light bar control cable and the smaller cable is the SignalMaster control cable.

The lightbar is completely wired at the factory and does not require any additional internal wiring. All the conductors necessary for control of any and all basic and optional functions are contained in the cable.

The basic light functions of the unit must be controlled by a user-supplied control head.

Before proceeding, ensure that the lightbar has been installed on the vehicle roof in accordance with the instructions packed with the mounting kit.

 **WARNING**

Light system controls must be located so that VEHICLE and CONTROLS can be operated safely under all driving conditions.

A. Route the control cable into the vehicle and under the dash, near the eventual location of the user-supplied control head.

B. For proper light operation, the control cable must be properly terminated inside the user-supplied control head. Using figure 1 and table 1 as a guide, make the appropriate electrical connections. Ensure that the lines are adequately fused as shown, and that switch capacity is adequate for the current requirement.

CAUTION

Reverse polarity may damage any power supply and prevent operation. Ensure that correct polarity is observed.

C. Connect the 10 gauge black lead from the main cable to the vehicle battery ground (-) terminal.

L.A.P.D. ARJENT SL REF. WIRING DIAGRAM

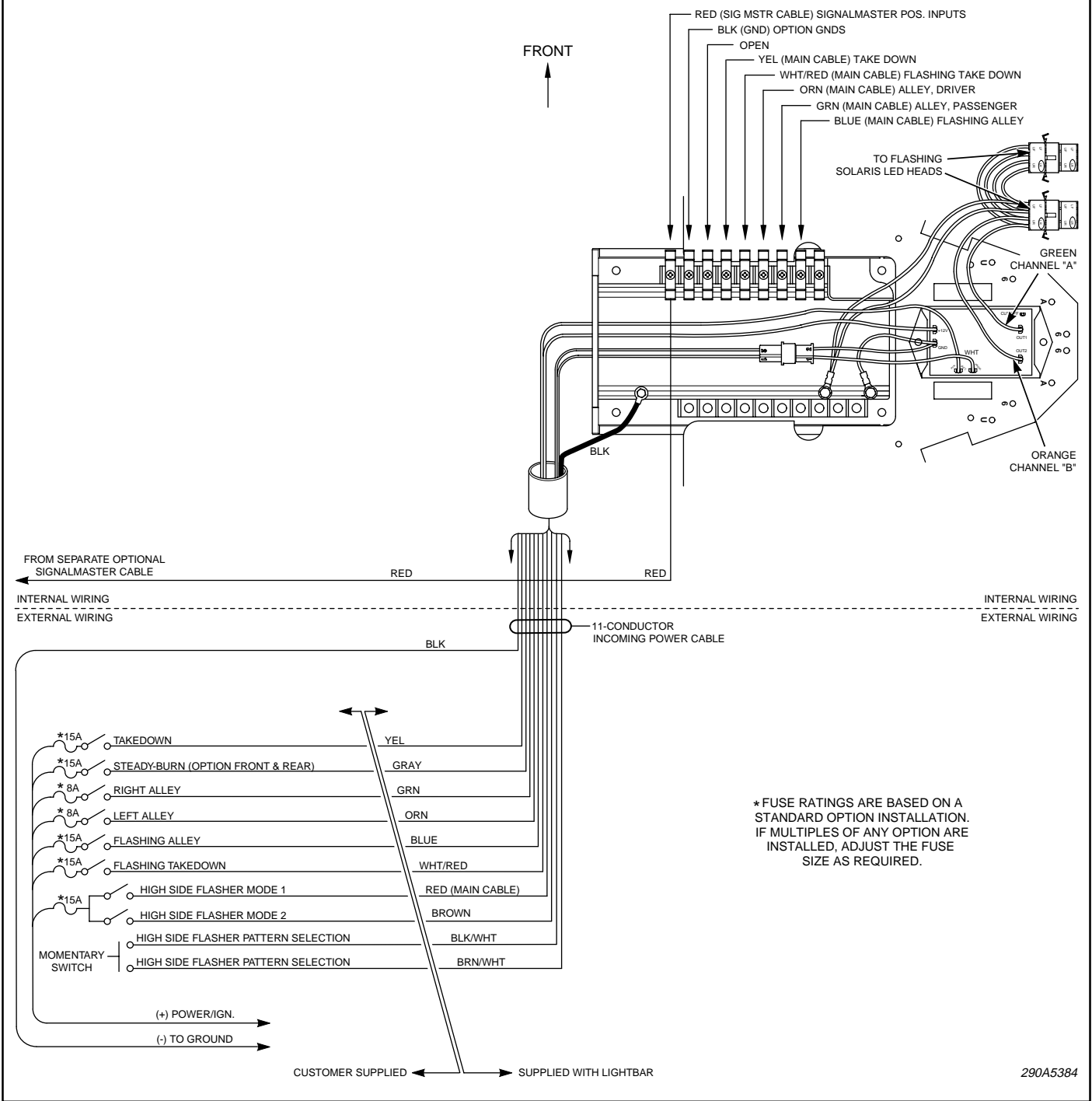

* FUSE RATINGS ARE BASED ON A STANDARD OPTION INSTALLATION. IF MULTIPLES OF ANY OPTION ARE INSTALLED, ADJUST THE FUSE SIZE AS REQUIRED.

290A5384

Figure 1.

Table 1. Electrical Connections.

Wire Color	Functions
BLK	Ground (-)
YEL	Takedown
GRAY	LED Module Steady Burn Terminals
GRN	Right Alley
ORG	Left Alley
BLU	Flashing Alley
WHT/RED	Flashing Takedown
RED	High Side Flasher Mode 1
BRN	High Side Flasher Mode 2
WHT/BLK	High Side Flasher Pattern Selection
WHT/BRN	High Side Flasher Pattern Selection

NOTE

All of the lightbar functions can be activated by applying 12VDC to the appropriate control line. The heavy black lead (-) must be connected to battery ground, to perform a function check.

D. *SignalMaster Option.*

The SignalMaster option is completely wired at the factory and does not require any additional wiring inside the light bar. All conductors necessary for control of the SignalMaster are contained in the smaller cable.

For wiring and operation instructions, refer to the instruction sheet packed with the applicable SignalMaster control unit.

E. *Programming High Side Flasher Option (see table 1).*

⚠ WARNING

DO NOT connect flasher to brake light circuit of ANY vehicle.

DO NOT connect flasher to the headlight circuit of any vehicle.

Connection of aftermarket electrical equipment into this circuit may interfere with the brake shift interlock.

This could cause the vehicle to unexpectedly move forward causing possible property damage, injury or death to the vehicle operator or others.

The flasher will provide the end user with two preselected flash patterns. The preselected flash patterns are to be chosen from the eight factory programmed patterns provided with each flasher. It is recommended that the preselected flash patterns be determined and programmed during installation. One steady-on setting is also provided. SAE compliant patterns will be noted by a green LED on a powered flasher assembly.

Refer to table 1 for proper wire colors for pattern selection and power inputs. The following procedures

demonstrate the programming and operating features of the flasher:

Apply power to Mode 1 input of the flasher. Momentarily short the pattern selection wires until the desired pattern is running. Allow the pattern to run for 15-seconds; Mode 1 is now programmed.

Apply power to both Mode 1 and Mode 2 of the flasher. Momentarily short the pattern selection wires until the desired pattern is running. Allow the pattern to run for 15-seconds; Mode 2 is now programmed.

III. BASIC MAINTENANCE.

⚠ WARNING

High voltages are present inside the lightbar. Wait at least ten (10) minutes, after shutting off power, before servicing this unit. Failure to do so may result in property damage, serious injury, or death to you or others.

Disconnect ALL power to the lightbar before any maintenance is performed.

A. *Cleaning the Plastic Domes.*

Ordinary cleaning of the plastic domes can be accomplished by using mild soap and a soft rag. Should fine scratches or a haze appear on the domes, they can ordinarily be removed with a non-abrasive, high quality automotive paste wax.

⚠ WARNING

Crazing (cracking) of domes will cause reduced effectiveness of light system. Do not use cleaning agents (which will cause crazing) such as strong detergents, solvents, or petroleum products. If crazing of domes does occur, reliability of light for emergency warning purposes may be reduced until domes are replaced.

B. *Halogen Lamp Replacement.*

⚠ WARNING

A serious injury may result if lamp is touched when hot. Always allow lamp to cool before removing. Halogen lamps are pressurized and if broken can result in flying glass. Always wear gloves and eye protection when handling the lamps.

CAUTION

Service life of lamp will be shortened if glass portion is touched. If glass has been handled, clean carefully with a grease solvent.

See figures 2 and 3. Refer to table 2 and replace the defective lamp with an exact replacement only.

C. *Cleaning Reflector Assemblies.*

Use a soft tissue to clean the reflectors. Avoid heavy pressure and the use of caustic or petroleum base solvents which will scratch or dull the surface.

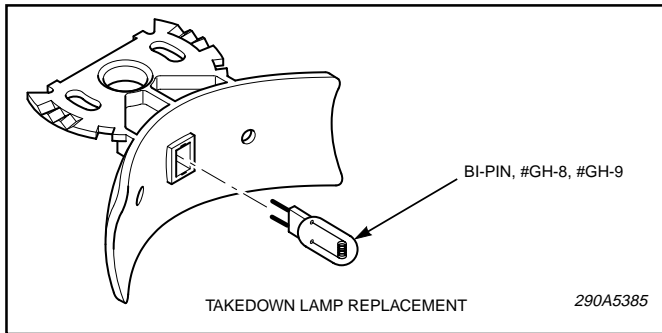

Figure 2.

Table 2.

FUNCTION	REPLACEMENT LAMP
Takedown	50W Halogen, GH-8 (bi-pin) Part No. 8107169
Alley	35W Halogen, MR11 Part No. 8107241
SignalMaster	Solaris Gen-3 LED Amber Module Assy. Part No. 8583337-02
Solaris 6 Button LED Gen-3	Replacement Module Amber-Part No. 8583337-02 Blue-Part No. 8583337-03 Red-Part No. 8583337-04 White-Part No. 8583337-05
Solaris 9 Button LED Gen-3	Replacement Module Amber-Part No. 8583336-02 Blue-Part No. 8583336-03 Red-Part No. 8583336-04 White-Part No. 8583336-05

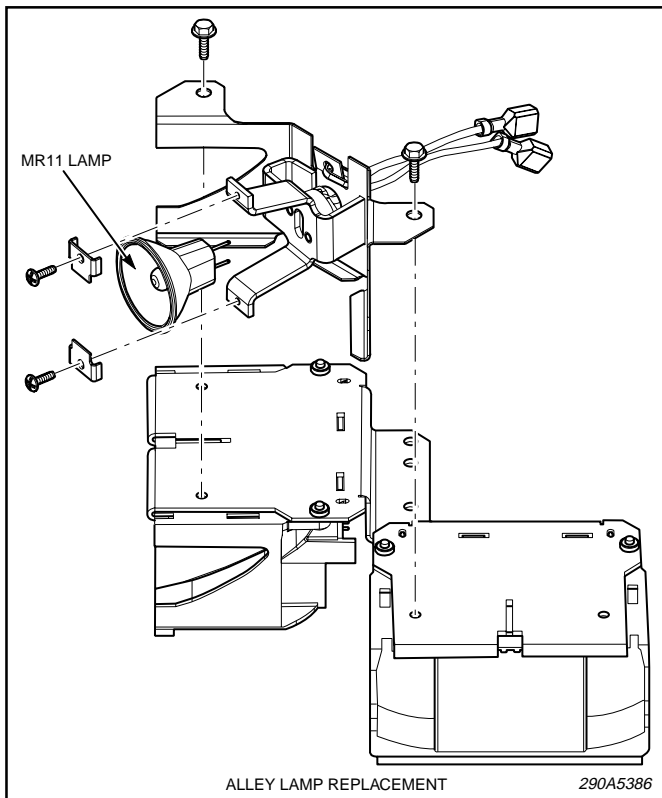

Figure 3.

D. *LED Assembly Replacement.*



A serious injury may result if LED assembly is touched when hot. Always allow LED assembly to cool before removing.

Solaris Gen-3 LEDs.

See figure 4. Refer to table 2 and replace the defective LED assembly with an exact replacement only.

Copyright 2005 Federal Signal Corporation

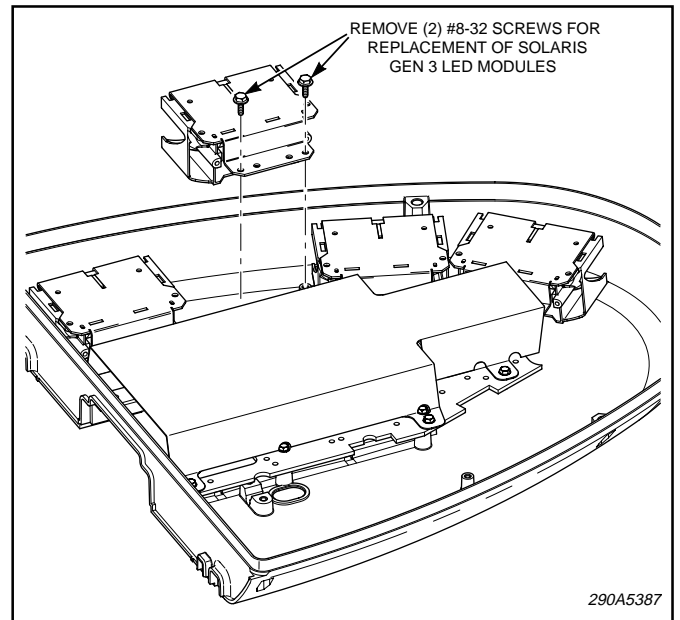

Figure 4.